

# The NORTH EASTERN EXPRESS



INDEX TO ISSUE Nos. 145 – 168  
ISSN 0962 – 8746

## NER Class K

Standard boiler and safety valve position

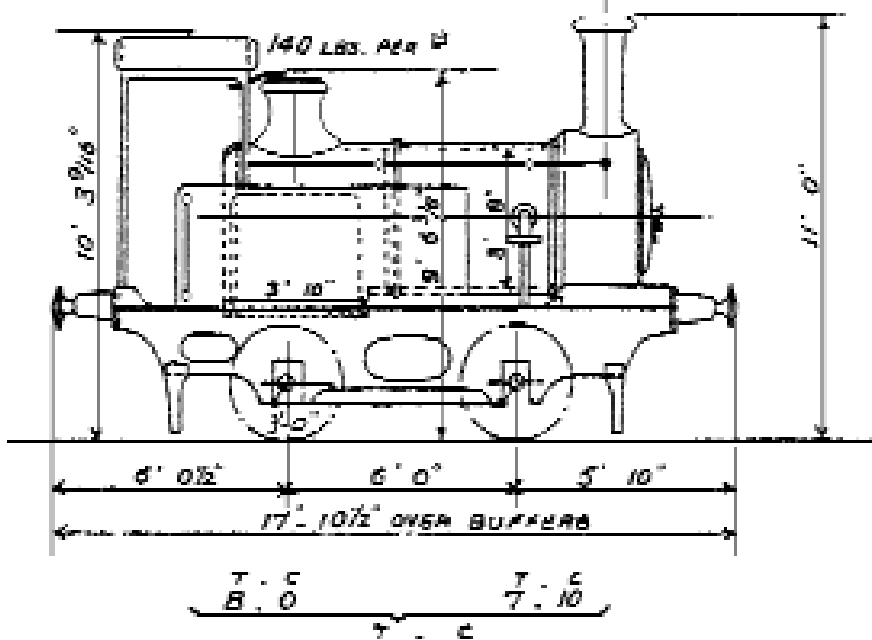

*(i) Museum Collection*

The Journal of the  
NORTH EASTERN RAILWAY ASSOCIATION

## INTRODUCTION

All major articles, book reviews and letters appearing in the *North Eastern Express* issue numbers 145 – 168 are listed within this Index. The majority of the drawings, maps and photographs appearing in those issues are also listed in a separate Appendix.

Index entries refer to the number of the individual Journal and to the first page on which the item appears. Thus entry 153/27 indicates Journal N° 153, page number 27.

---

### NORTH EASTERN RAILWAY ASSOCIATION

Formed in 1961, the North Eastern Railway Association caters for all interested in the railways of North-East England, in particular the North Eastern Railway and the Hull & Barnsley Railway, from their early history down to the present day. This also extends to the many industrial and smaller railways that operated alongside them. Interests range over all aspects of development, operation and infrastructure of the railway, including such diverse activities as locomotive history, rolling stock, train services, architecture, signalling, shipping, road vehicles and staff matters – both for the general enthusiast and the model maker.

With in excess of 700 members, regular meetings are held in York, Darlington, Hull and London. A programme of outdoor visits, tours and walks is also arranged.

Members receive a quarterly illustrated journal, the *North Eastern Express*, and a newsletter covering membership topics, forthcoming meetings and events in the region together with book reviews and a bibliography of recent articles of interest. Over 180 issues of the *Express* have been published to date.

The Association owns an extensive library of books, documents, photographs and drawings. The Association also markets an extensive range of facsimiles of NER documents, including diagram books, timetables and other booklets, while at the same time it is developing an expanding range of original publications, available to members at discounted prices.

For details of membership, please contact :

Mr T Morrell, 8 Prunus Avenue, Kingston Road, Willerby, Hull, HU10 6PH.

For a sales list of other NERA publications, please contact :

Mrs CE Williamson, 31 Moreton Avenue, Stretford, Manchester, M32 8BP.

(Please enclose a stamped addressed 9" x 4" envelope  
with your request for a sales list.)

---

**Published by the North Eastern Railway Association**

**2007**

ISSN 0962 8746

**100 Years Ago** – a Tyneside Railway Calendar ..... 154/67

## **Accidents**

Railway Accidents in the Second Half of 1851 ..... 163/87

### **NER**

Locomotives in Incidents at Wear Valley Junction and Crook,  
1881 to 1904 ..... 156/118

S&D Crossing, 7 September 1863 ..... 147/55

St Nicholas Crossing, Carlisle, 10 July 1870 ..... 154/57

Wrecking of “Flying Scotsman” in Washington, 16 July 1864 . 155/95

### **LNER**

Burton Agnes, 17 September 1947 ..... 164/126

Naworth Level Crossing, 30 August 1926 ..... 156/123

**Bend**, Round the [locomotives permitted to traverse Whitby Branch] 145/21

## **Book and Video Reviews**

*Chronicle of the Stockton & Darlington Railway to 1863.*

John H Proud ..... 153/27

*Detailed History of British Railways Standard Steam Locomotives.*

*Volume 3: the Tank Engine Classes.* RCTS. ... 152/128

*Eden Valley Railway.* Robert Western. .... 148/103

*High Level Bridge and Newcastle Central Station.*

John F Addyman , Bill Fawcett *et al* .... 156/141

*History of North Eastern Railway Architecture.*

*Volume 1: The Pioneers.* Bill Fawcett .... 163/111

*Locomotives of the Hull and Barnsley Railway.* Ron Prattley. ... 149/20

*Locomotives Illustrated 120. The LNER Class L1 2-6-4Ts*

*and the K1 2-6-0s.* ..... 152/127

*Malton & Driffield Railway.* Warwick Burton. .... 149/20

*North Eastern Record. Volume 2.* ..... 147/61, 147/71, 149/18

*North Eastern Record. Volume 3.* ..... 160/118

*North From Newcastle [video]* ..... 150/76

*Railways Around Whitby, Volume 2.* Martin Bairstow. .... 145/19

*Railways of Harrogate and District.* James Rogers ..... 160/119

*Railways to New Holland and the Humber Ferries.* AJ Ludlam. .. 147/71

*Scenes from the Past: 30 (Part One)*

*BR Camping Coach Holidays.* Andrew McRea. .... 148/104

*World's Most Famous Steam Locomotive, Flying Scotsman.*

David Clifford. .... 148/103



Crimple Viaduct . . . . .	164/132
High Level Bridge, Researching the . . . . .	155/83
<b>Buffer Stops</b> – NER and LNER . . . . .	161/40
<b>Butterworth, GS Kaye</b> . . . . .	150/64
<b>Café Andros, GT Andrew’s Office</b> . . . . .	153/29, 154/61
<b>Carriages</b>	
Clerestory in BR departmental service . . . . .	148/106, 149/22
Colour of NER . . . . .	165/23
Diagram 5 Clerestory Coach . . . . .	146/41, 148/101, 148/102, 150/70
Distinguishing First Class on the NER . . . . .	165/34
NER Coach Codes . . . . .	151/94
NER Lavatory 3 <sup>rd</sup> Carriages [Bungalow Hotel and Restaurant] . . . . .	157/17
NER Slip Carriage Services . . . . .	146/35, 149/8
North Eastern Railway Coach Group . . . . .	161/11
Rationale and Rigours of Renumbering . . . . .	156/114
S&DR Survivors . . . . .	167/87
York Carriage Works Returns to Life . . . . .	152/121
<b>Chaldron Wagons, Longevity of</b> . . . . .	148/97
<b>Check Labels</b>	
NER Bicycle Check Label . . . . .	166/74
<b>Circus</b>	
Bertram Mills Circus . . . . .	167/95
<b>Civil Engineering</b>	
Crimple Viaduct . . . . .	164/132
Construction of the L&TR in the Vicinity of Harrogate . . . . .	163/99
Railway Civil Engineering Works in the Harrogate Area . . . . .	164/128
<b>Cliff Railways</b>	
Cliff Railways of the Yorkshire Coast . . . . .	166/69
<b>Coal</b>	
NER and the Coal Trade . . . . .	152/116
Never Take Coals to Newcastle? . . . . .	152/122
<b>Copyright</b> . . . . .	167/83
<b>Cottage Homes and Benefit Fund, NER</b> . . . . .	145/17
<b>Crime</b>	
East Riding, Crime in the [re detective fiction] . . . . .	150/45
Murder on an NER train, 1910 . . . . .	166/70
Müller’s Lights [see above] . . . . .	167/121
<b>Directors’ Residences</b> . . . . .	150/58

## **Docks**

Middlesbrough Dock .....	159/75, 160/114, 161/35, 162/65
Tyne Dock .....	150/64, 151/91, 152/108

## **Electric Multiple Units**

Electric Motor Third with “Collywell Bay” Destination Blind ...	149/22
---	--------

## **Electrification**

Railway Electrification on Tyneside 1902 – 1967 .....	167/97
---	--------

## **Engine Sheds**

Alexandra Dock Shed, Hull, in the 1950s .....	152/117
Kirkby Stephen Depot in the Fifties .....	162/68
Some Thoughts on Ferryhill Locomotive Shed .....	166/43

<b>Fate, a Twist of</b> .....	152/115
-------------------------------	---------

<b>Fifty and More Years Ago</b> .....	156/143
---------------------------------------	---------

## **Fires**

Leeds New Station, 13 January 1892 .....	160/107
Nidd Hall, 15 June 1880 .....	152/107
Wellington Street Goods Depot, 25 August 1872 .....	156/111

## **First World War**

Contribution by the NER to the BEF in France .....	158/40
Inness, RH, in France During the First World War .....	161/31
NER Recruiting .....	167/110
Track Singlings .....	161/17
War Memorial .....	155/83, 157/87

<b>Foot-and-Mouth Disease</b> [1863 NER Circular] .....	162/78
---	--------

<b>Harrogate’s Ghost Railway</b> .....	148/89
--	--------

<b>Harrogate and Starbeck, North Eastern Memories</b> .....	168/139
---	---------

<b>Harrogate Station</b> .....	167/121
--------------------------------	---------

<b>Harrogate, who was Who in?</b> .....	151/89
---	--------

<b>Head Office, S&amp;DR</b> .....	159/83
------------------------------------	--------

<b>Hudson, George, His Last Battle</b> .....	157/3
--	-------

## **Letters** [main topics only]

Aire Bridge, Brotherton .....	152/125
Alexandra Dock in the 1950s .....	153/26
Bertram Mills Circus .....	168/161
Bridges Junction, Hull .....	162/73, 164/136
Cabry Family .....	157/29

Castle Eden at the Turn of the Century .....	145/22
Class 4CC Locomotives .....	159/100
Class 59 Locomotive N° 1102 .....	159/100
Clearances, York District bridge and tunnels .....	162/73
Coal Trade and the NER .....	153/26
Collywell Bay Branch .....	150/70, 151/96, 152/125, 156/143
Day Line Diesel Ticket .....	168/161
Diagram P4 Coal Wagon .....	152/124
Diagram V3 six-wheel Brake Van .....	155/98
Ferryhill Signal Gantry .....	163/112
Horse Boxes and Fish Vans .....	162/76
Leeds and Thirsk Railway Viaducts .....	159/100
Leeds, Castleford and Pontefract Junction Railway .....	155/97
Level Crossings, Boom Gates .....	162/75
Middlesbrough Dock .....	161/41
NER Lines and Stations .....	157/29
NER Recruiting [First World War, New Army] .....	168/161
New Bridge, Pickering – Levisham Single Line .....	166/59, 168/161
Newcastle, Mysterious Railway Plans at .....	154/65
Railway Rateable Values .....	168/160
S&DR N° 27 .....	161/41
Signal Cabins, NER .....	152/123
Wagon Repair in the Harrogate and York Areas .....	157/29

## **Level Crossings**

Level Crossings – Boom Gates .....	161/14
Level Crossings in General, that at Starbeck in Particular .....	162/60

## **Locomotives**

Locomotives of the Clarence Railway .....	148/82
Locomotives of the Stockton and Hartlepool Railway	
Part 4 .....	146/27
Part 5 .....	147/58
Part 6 .....	148/86
Sir Vincent Raven's Diagram Book .....	148/92, 149/7, 152/120

## **LNER**

Class V2 N° 60964, the Naming of .....	154/56
--	--------

## **NER**

0-6-0 Locomotive N° 430 .....	160/130
Class 59 N° 192 .....	161/17
Class 59 N° 522 .....	158/54
Class 964A N° 873 .....	157/17

Class A Locomotive, Modelling the NER . . . . .	161/11
Class C, C1 and J21 [notes re supplementary drawings] . . . . .	146/41
Compound Atlantics on the Waverley Route . . . . .	163/104
Decorated BTP Locomotive . . . . .	165/22
Heavy Shunting Tank Locomotive [NER Class X] . . . . .	150/35
NER Pacifics and the late RH Inness . . . . .	168/159
Smith Compound Locomotives . . . . .	157/15, 160/130
Short Wheelbase 2-4-0s Tried on the Whitby Branch . . . . .	167/121

**S&DR**

An Unknown Engine [S&DR N° 27] . . . . .	159/85
<b>LNER</b> , North Eastern Area, Recollections of . . . . .	152/113

**Middlesbrough Dock** . . . . . 159/75, 160/114, 161/35, 162/65

**Model Topics** (published in each issue of the *Express*)

BR 56 ton Iron Ore Wagons . . . . .	157/31
Brodsworth Main Colliery PO wagon . . . . .	166/77
H&BR Locomotives . . . . .	146/32
H&BR Meat Van . . . . .	162/79
Hensall Junction Engine Shed . . . . .	167/122
NER Class E1 Locomotive . . . . .	151/97, 153/28
NER/H&BR Class K Locomotives . . . . .	160/132
Private Owner Coal Wagons . . . . .	159/101
Terminology . . . . .	165/37
Transfers . . . . .	152/126
Wagons and Vans in 4mm Scale . . . . .	147/67
WD Class 2-8-0 from Bachmann . . . . .	158/69

**Newcastle upon Tyne**, Mysterious Railway Plans at . . . . . 153/24

**News in Brief** (published in each issue of the *Express*)

**North Eastern Railway Association**

Forty Years On – A personal view of the NERA . . . . .	161/3
--	-------

**Obituaries**

Bowtell, Harold D . . . . .	154/55
Coiley, John A . . . . .	153/2
Dawson, John B . . . . .	157/3
Hunter, RJ . . . . .	155/71
Taylor, Kenneth L . . . . .	158/39



## **Personalities**

Gresley, Sir HN .....	149/21, 168/157
Hoole, Ken .....	155/70
Inness, the late RH .....	163/109
Stork, the late James Boynton .....	160/116

<b>Pickering, Along by</b> .....	149/21
----------------------------------	--------

<b>Plagiarism, a Case of ?</b> .....	154/44
--------------------------------------	--------

<b><i>Railway Magazine</i>, Centenary of</b> .....	147/51
--	--------

## **Railwaymen and Women**

Last Stationmaster of Benton and Whitley Bay .....	154/63
--	--------

## **Raven, Sir VL**

Raven Down Under .....	150/73
Sir Vincent Raven's Diagram Book .....	148/92, 149/7, 152/120

## **Road Vehicles, NER**

Convertible Road Engine .....	165/20
Garrett Steam Road Vehicles .....	145/7
Leyland Omnibus .....	164/133
Minor Mystery Solved .....	161/40, 165/18

<b>Rosedale Branch, Gradient Profiles</b> .....	156/107
---	---------

<b>Rolling Stock, N° 150 – a Survey of</b> .....	150/50
--	--------

<b>Royal Persons</b> .....	159/86
----------------------------	--------

## **Second World War**

How The War Was Won .....	166/53
NER to the Rescue Once Again .....	165/14

<b>Share Certificates, NER</b> .....	150/69
--------------------------------------	--------

## **Signal and Telecommunications**

Archives, Down Among the .....	148/92
Early NER Signalling .....	145/10
For Want of a Nail .....	166/44
Miles Wright Correspondence Books, Part 1 .....	164/119
Miles Wright Correspondence Books, Part 2 .....	166/49
Saloon Specials .....	148/79
Signal Cabins, NER .....	150/59

## **Stations**

Brierdene .....	147/65
Fence Houses .....	149/3
Harrogate Station [in 1901] .....	167/121
Leeds 1 <sup>st</sup> : a £165M Project by Railtrack .....	161/27

Newcastle Central Station, the Opening of . . . . .	156/140
Newcastle Central Station, Researching . . . . .	155/83
Sprouston . . . . .	145/19
Tynemouth, Sesquicentenary . . . . .	147/64
<b>Stockton and Darlington Railway</b> [see also other entries such as <b>Locomotives</b> ]	
Engineers of the . . . . .	150/53
Head Office . . . . .	159/83
<b>Tickets/Check Labels</b>	
NER Bicycle Check Label . . . . .	165/22, 166/74
<b>Train Journeys</b>	
All For Fifteen Bob! [Day Line Diesel Ticket] . . . . .	161/21
Along by Pickering . . . . .	148/84
On the Footplate – Tyne Dock – Consett . . . . .	150/49
<b>Train Operating</b>	
American influence on the NER . . . . .	165/3
Barnard Castle Goods Yard, Train Movements into, 1915 - 16 . . .	148/90
Bertram Mills Circus . . . . .	167/95
How The War Was Won [Second World War] . . . . .	166/53
NER to the Rescue Once Again [Second World War] . . . . .	165/14
NER Slip Carriage Services . . . . .	146/35, 149/8
Passenger Services on the Wear Valley Branch in 1935 . . .	161/5, 162/77
Redcar Race Special . . . . .	168/132
Storm Force on the ECML [January 2002] . . . . .	167/84
York to Hull Fast – only on Sundays . . . . .	148/96
<b>Tyne Dock</b> . . . . .	150/64, 151/91, 152/108
<b>Wagons</b>	
Wagon Repair in the Harrogate and York Areas . . .	154/35, 155/71, 156/136, 157/4
<b>NER</b>	
Dgm A1 Implement . . . . .	165/35, 166/57
Dgm C2 High Goods . . . . .	167/117
Dgm D2 Single Bolster . . . . .	156/110
Dgm P4 Coal . . . . .	149/12
Dgm P5 Mineral (early pattern) . . . . .	163/107
Dgm R1 Coke . . . . .	164/124
Dgm R3 Coke (early pattern) . . . . .	162/72
Dgm V1 Brake Van . . . . .	167/119

Dgm V1 Brake Van, Modifications to .....	165/18
Dgm V2 Brake Van .....	166/56
Dgm V3 6-Wheel Brake Van .....	154/59
<b>War Memorials, NER</b> .....	153/12
<b>Works</b>	
York Carriage Works Returns to Life .....	152/121
<b>Yeadon, Willie B</b>	
My Memories of .....	161/23
WB Yeadon LNER Collection .....	150/72

## APPENDIX

### DRAWINGS and MAPS

The majority of the drawings and photographs in issues 145 – 168 are listed. The following abbreviations are used: cv – cover; bc – back cover; ifc – inside front cover; ibc – inside back cover; s – issued loose as a supplement.

#### Architectural Drawings

##### NER

Brierdene Station .....	147s
Cottage .....	161s
Kirkby Stephen Engine Shed .....	162s
Sunderland South Dock Engine Shed .....	158s

##### Bridges

Aire Bridge, Brotherton, cross-section of tube .....	151/ibc
Tay Bridge, Perth, cross-section through .....	164/ibc

##### Buffer Stops

LNER, 1943 .....	161s
NER .....	161s, 165s

##### Carriages

##### NER

Composite Bogie .....	146s
Van Composite Bogie .....	149s

**Collywell Bay Branch** .....

145/5, 148/94, 152/ibc

**Darlington, S&D Crossing** .....

164/ibc

**Dunston Area, Collieries in the** .....

167s

##### Engine Sheds

Alexandra Dock, Hull .....	152s
Kirkby Stephen .....	162s



## NER

Dgm A1 Implement . . . . .	165s
Dgm C2 High Goods . . . . .	167s
Dgm D2 Single Bolster . . . . .	156s
Dgm P4 Mineral . . . . .	149s
Dgm P5 (early pattern) . . . . .	163s
Dgm R1 Coke . . . . .	164s
Dgm R3 Coke (early pattern) . . . . .	162s
Dgm V1 Brake van (late pattern) . . . . .	167s
Dgm V2 Brake Van (speculative) . . . . .	166s
Dgm V3 Brake Van . . . . .	154s

## Private Owner

Draw Gear . . . . .	155s
---------------------	------

## PHOTOGRAPHS

### Bridges

Aire Bridge, Brotherton . . . . .	151/cv
Aire Bridge, Castleford . . . . .	153/ifc

### Carriages

#### S&DR

Four-wheel carriages in departmental use . . . . .	167/ifc
--	---------

#### NER

Camping Coaches [LNER period] . . . . .	146/44
Carriage N° 1581 at Riccall, circa 1902 . . . . .	164/bc
Clerestory in BR departmental service . . . . .	148/106
Various, hauled by an unidentified locomotive of Class G . . . . .	162/ifc

<b>Check Label</b> [NER, Bicycle] . . . . .	165/ifc
---	---------

### Cliff Railways

Queen's Parade Cliff Railway, Scarborough . . . . .	166/cv
---	--------

<b>Cottage</b> , Hedgeley Station . . . . .	161/16
---	--------

<b>Darlington Works</b> [Shell Factory] . . . . .	158/ifc
---	---------

### Docks and Quays [see also Tug Boats and Dredgers]

Middlesbrough . . . . .	159/cv, 159/ifc, 159/88, 159/89
Newcastle Quayside . . . . .	145/bc, 146/ifc, 146/31

### Electric Multiple-Units

Tyneside 3 <sup>rd</sup> rail . . . . .	148/bc, 161/ifc [hand-tinted postcard], 167/96, 167/102
---	---

### Engine Sheds

Ferryhill . . . . .	166/bc
Gosforth Car Shed, Repair Shop . . . . .	168/156

Kirkby Stephen .....	162/67
Sprouston .....	145/ibc
<b>Goods Sheds</b>	
Marske .....	166/ibc
Redcar .....	166/ibc
<b>Harrogate Gas Works</b>	
<i>Barber</i> plus tank wagons .....	155/cv, 155/bc
Coal drops .....	155/bc
<b>Head Office, S&amp;DR</b> .....	159/bc
<b>Hensall Junction</b> .....	167/ibc
<b>Inspection Saloons</b> .....	146/cv, 148/ifc
<b>Level Crossings</b>	
Boom Gates .....	161/15
<b>Locomotives</b>	
<b>BR</b>	
WD Class N° 90011 at Bridlington .....	168/cv
<b>H&amp;BR</b>	
Class F1 N° 99 .....	146/33
Class J as NER N° 3038 .....	168/bc
Class K .....	146/33
<b>LNER</b>	
Class A3 as BR N° 60086 at the head of a passenger train . . . .	150/48
Class A4 at the head of <i>The Flying Scotsman</i> [BR period] . . . .	162/bc
Class D49 as BR N° 62727 at the head of a passenger train . .	150/48
Class D49 as BR N° 62730 at the head of an empty coal train .	148/85
Class E4 N° 7416 under repair at Kirkby Stephen .....	146/45
Class J39 piloting WD Class on a freight train [BR period] . . .	158/ibc
Class V2 N° 60964 being named, April 1958 .....	154/ibc
Class Y1 N° 174 at Bridlington .....	167/cv
<b>L&amp;YR</b>	
Aspinall 0-6-0 as BR N° 52319 working an Engineer's train, Little Weighton cutting . . .	162/ibc
<b>NER</b>	
<i>Aerolite</i> on display in the NRM [in colour] .....	150/bc
Class 4CC N° 730 .....	165/ibc
Class 4CC as LNER C8 N° 730 .....	148/bc
Class 4CC N° 731 on shed, Haymarket .....	165/bc
Class 13 N° 430 .....	160/131
Class 41 N° 85 at Stella Gill .....	167/109
Class 59 N° 192 .....	161/16

Class 59 N° 522	158/55
Class 59 N° 1102	156/127
Class 93 N° 516	166/60
Class 124 N° 610	166/61
Class 290 N° 1313	157/bc
Class 398 N° 200 at Percy Main	166/60
Class 398 N° 815 at Tyne Dock	167/109
Class 708 N° 760	156/126
Class 964A N° 873	157/19
Class A [model]	161/10
Class BTP N° 288 decorated at Newcastle	165/22
Class E shunters at Middlesbrough Dock [BR period]	160/121
Class E as LNER Class J21 [model]	151/98
Class E1 [model]	153/28
Class H N° 1310 on the preserved Tanfield Railway	162/ifc
Class K	160/120
Class M cab interior [in colour]	161/bc
Class M1 N° 1629 at Newcastle Central	166/61
Class P as BR Class J24 N° 65656 at the head of a freight train	148/cv
Class P1 N° 2071 in Works Grey	157/bc
Class R N° 2033 at the head of a passenger train	157/cv
Class R N° 2101	157/ifc
Class R as BR N° 62386 piloting V2 on a passenger train	162/bc
Class S1 N° 2112 at the head of a passenger train [coloured lantern slide]	150/bc
Class T2 as LNER Class Q6 [model]	160/121
Class V N° 784 at the head of a passenger train [hand-tinted postcard]	150/cv
Class V/09 N° 698 at the head of a passenger train [hand-tinted postcard]	161/cv
Class X	150/ifc <i>et seq.</i>
Class X N° 1359 as BR Class T1 N° 69917 at Tyne Dock	152/bc

## ROD

Belgian Type 25 plus soldiers including the late RH Inness	161/33
Kerr Stuart & Company Limited Works N° 3068 of 1917	163/cv

## S&DR

0-6-0 N° 25 <i>Derwent</i> at Darlington, 1925	162/cv
0-6-0 N° 27	159/bc

## Sandtoft Quarries

Ruston & Hornsby 2' gauge diesel locomotive	149/ibc
---	---------

<b>Seaham Harbour Dock Company</b>	
0-4-0ST N° 18 [in colour] . . . . .	161/bc
<b>War Department</b>	
N° 73662 on a troop train at Breda, Holland . . . . .	165/cv
WD Class N° 90011 at Bridlington [BR Period] . . . . .	168/cv
<b>West Hartlepool Railway</b>	
N° 19 <i>Wear</i> . . . . .	148/87
N° 41 <i>Alexandra</i> . . . . .	148/87
<b>Members and Friends</b>	
Bowtell, Harold D, ENC Haywood and Dr A Barnett . . . . .	155/87
Fleming, John F and family . . . . .	164/cv
Hunter, Robert J and others . . . . .	161/34
Inness, Dick and Les Charlton . . . . .	163/ifc
MacLean, John S and his wife . . . . .	161/34
Stork, James B . . . . .	160/120
Taylor, Kenneth L . . . . .	163/ifc
Wilson, Ann, on the occasion of her retirement . . . . .	166/76
Yeadon, Willie B, Allan Grey and Allan Crompton . . . . .	161/33
Group photograph, 4 October 1997 . . . . .	149/ifc
Group photograph, 5 May 2001 . . . . .	163/bc
<b>Middlesbrough Dock</b> . . . . .	159/cv, 159/ifc, 159/88, 159/89
<b>New Bridge</b> [Whitby Branch] . . . . .	165/ifc
<b>Nunthorpe East Junction</b> 21 March 1959 . . . . .	164/ifc
<b>Railcars, Steam</b>	
LNER N° 226 <i>Ebor</i> at Cudworth . . . . .	156/ifc
<b>Railwaymen and Women</b>	
17 <sup>th</sup> (Service) Battalion, Northumberland Fusiliers (NER) . . . . .	158/ifc
Gibb, George Stegmann . . . . .	147/53
S&T staff at York, 1962 . . . . .	166/45
Wagon Repairers at Stonefall Sidings, 1950s . . . . .	154/ifc
Wagon Repairers at Hunslet Wagon Works circa 1925 . . . . .	155/81
<b>Road Vehicles</b>	
<b>NER</b>	
Convertible Road Engine . . . . .	165/21
Kitchen Wagon [as built by NER for the New Army] . . . . .	158/ifc
Leyland Omnibus . . . . .	164/ifc
Omnibuses converted for use as lorries by War Department . . . . .	158/bc
<b>Rosedale Branch</b>	
East Rosedale circa 1900 . . . . .	163/109
Near Reeking Gill, 1999 . . . . .	155/ibc



## Signal and Telecommunications

Belmont Crossing, Gate Box and House . . . . .	163/ibc
Brierdene Signal Box . . . . .	150/71
Fence Houses Signal Box . . . . .	149/17, 153/cv, 153/bc
Nail being used to take up wear in a signal's linkage . . . . .	166/45
Pickburn Signal Box . . . . .	165/ibc
S&D Crossing Signal Box . . . . .	147/bc
Seamer Signal Box . . . . .	163/ibc
Seaton Sluice Signal Box . . . . .	148/93
Sprouston Signal Box [interior] . . . . .	145/ibc

## Starbeck South Junction . . . . . 162/66

## Steam Railcars . . . . . 147/cv

## Stations

Brierdene . . . . .	150/71
Fence Houses . . . . .	149/17
Leeds New . . . . .	161/24, 161/26
Leeds City . . . . .	156/ibc, 161/ibc
Malton, temporary platform installed following floods in 1999 . . . . .	155/ifc
Monkseaton [original station, not NER replacement of 1915] . . . . .	151/bc
Newcastle Central [postcard] . . . . .	155/99
Pickering [architectural model] . . . . .	150/ibc
Sandsend [hand-tinted postcard] . . . . .	161/ifc
Selby, plaque on Leeds & Selby Railway trainshed wall . . . . .	163/bc
Sprouston . . . . .	145/ifc
Tynemouth . . . . .	167/96

## Thirsk South Junction . . . . . 145/cv

## Tickets/Check Labels

BR Day Line Diesel Ticket . . . . .	165/ifc
NER Bicycle Check Label . . . . .	165/ifc

## Track Renewal Train, Jarvis . . . . . 157/ibc

## Tug Boats and Dredgers

<i>Cleveland</i> , Middlesbrough Dock, during the First World War . . . . .	160/ifc
<i>Hutton</i> , Middlesbrough Dock, circa 1894 . . . . .	160/ifc
<i>NER N° 2</i> , Middlesbrough Dock . . . . .	160/bc
<i>NER N° 3</i> . . . . .	160/bc
<i>Nunthorpe</i> , Middlesbrough Dock Cut, circa 1926 . . . . .	160/cv
Dredger <i>David Dale</i> , Middlesbrough Dock Cut . . . . .	160/ibc

## Wagons

### BR

56 ton Iron Ore ..... 157/32

### EWSR

100 ton Steel Coil Carrier ..... 152/cv

### NER

Dgm A1 Implement ..... 166/ifc

Dgm A18 Rectank ..... 158/cv

Dgm D1 Single Bolster ..... 156/bc

Dgm C2 High Goods ..... 167/bc

Dgm G7 Van [as converted to convey wounded soldiers] ..... 158/bc

Dgm P4 Coal ..... 149/bc

Dgm P5 Mineral ..... 162/ibc, 163/109

Dgm P7 Mineral ..... 147/ifc

Dgm P8 Mineral ..... 147/ifc

Dgm Q3 Coal with side doors ..... 147/ibc

Dgm V1 Brake Van ..... 165/ibc, 167/bc

Dgm V2 Brake Van ..... 166/ifc

Dgm V3 6-Wheel Brake Van ..... 154/bc

### Private Owner

Brodsworth Main Colliery N° 350 ..... 166/76

Bullcroft Colliery N° 288 [model] ..... 159/ibc

**War Memorial, York** ..... 155/87